

THE **JOB PRO**[®] by Mi-T-M[®]

8650 Enterprise Drive, Peosta IA 52068
563-556-7484 / Fax 563-556-1235

JP-SERIES **OPERATION MANUAL** **COLD WATER DIRECT DRIVEN** **PRESSURE WASHER**



CAUTION

RISK OF INJURY!

READ MANUAL *BEFORE* OPERATING!

This manual is an important part of
the pressure washer and must
remain with this unit!



INTRODUCTION

Congratulations on the purchase of your new Job Pro® pressure washer! You can be assured your Job Pro pressure washer was constructed with the highest level of precision and accuracy. Each component has been rigorously tested by technicians to ensure the quality, endurance and performance of this unit.

This operator's manual was compiled for your benefit. By reading and following the simple safety, installation, operation, maintenance and troubleshooting steps described in this manual, you will receive years of trouble free operation from your new Job Pro pressure washer. The contents of this manual are based on the latest product information available at the time of publication. Mi-T-M® reserves the right to make changes in price, color, materials, equipment, specifications or models at any time without notice.

! IMPORTANT !

THESE PARAGRAPHS ARE SURROUNDED BY A "SAFETY ALERT BOX". THIS BOX IS USED TO DESIGNATE AND EMPHASIZE SAFETY WARNINGS THAT MUST BE FOLLOWED WHEN OPERATING THIS PRESSURE WASHER. ACCOMPANYING THE SAFETY WARNINGS ARE "SIGNAL WORDS" WHICH DESIGNATE THE DEGREE OR LEVEL OF HAZARD SERIOUSNESS. THE "SIGNAL WORDS" USED IN THIS MANUAL ARE AS FOLLOWS:

DANGER: INDICATES AN IMMEDIATELY HAZARDOUS SITUATION WHICH, IF NOT AVOIDED, WILL RESULT IN DEATH OR SERIOUS INJURY.

WARNING: INDICATES A POTENTIALLY HAZARDOUS SITUATION WHICH, IF NOT AVOIDED, COULD RESULT IN DEATH OR SERIOUS INJURY.

CAUTION: INDICATES A POTENTIALLY HAZARDOUS SITUATION WHICH, IF NOT AVOIDED MAY RESULT IN MINOR OR MODERATE INJURY.



THE SYMBOLS SET TO THE LEFT OF THIS PARAGRAPH ARE "SAFETY ALERT SYMBOLS". THESE SYMBOLS ARE USED TO CALL ATTENTION TO ITEMS OR PROCEDURES THAT COULD BE DANGEROUS TO YOU OR OTHER PERSONS USING THIS EQUIPMENT.

ALWAYS PROVIDE A COPY OF THIS MANUAL TO ANYONE USING THIS EQUIPMENT. READ ALL INSTRUCTIONS BEFORE OPERATING THIS PRESSURE WASHER AND ESPECIALLY POINT OUT THE "SAFETY WARNINGS" TO PREVENT THE POSSIBILITY OF PERSONAL INJURY TO THE OPERATOR.

Once the unit has been uncrated, immediately write in the serial number of your unit in the space provided below.

SERIAL NUMBER _____

Inspect for signs of obvious or concealed freight damage. If something appears to be damaged, file a claim with the transportation company immediately. Be sure that all damaged parts are replaced and that the mechanical problems are corrected prior to operation of the unit. If you require service, contact a Mi-T-M Customer Service Representative at 800-553-9053.

Please have the following information available for all service calls:

1. Model Number
2. Serial Number
3. Date and Place of Purchase

Mi-T-M® Corporation
8650 Enterprise Drive
Peosta, IA 52068-0050



IMPORTANT SAFETY WARNINGS

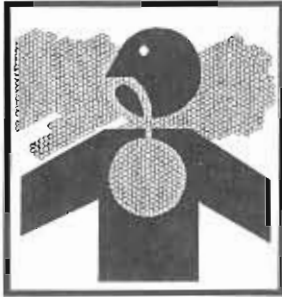

FIRE & VENTILATION PRECAUTIONS:

1. This unit was designed for outdoor use only. NEVER operate this unit in an enclosed area. ALWAYS make certain there is adequate air (oxygen) for combustion as well as ventilation to prevent the presence of poisonous carbon monoxide gases. Beware of poorly ventilated areas or exhaust fans which can cause inadequate combustion or engine overheating.
2. NEVER operate this unit in the presence of flammable vapors or combustible dust, gases or other combustible materials. (A spark may cause an explosion or fire.) When servicing this machine, be especially careful to properly dispose of any flammable materials. DO NOT spray flammable liquids.
3. ENGINE FUEL TANK:
 - a. **DO NOT SMOKE WHILE FILLING ENGINE FUEL TANK**
 - b. NEVER fill the engine fuel tank while the unit is running or hot. Allow the engine to cool two minutes before refueling.
 - c. DO NOT refuel indoors or in a poorly ventilated area.
 - d. ALWAYS refuel slowly to avoid the possibility of spilled fuel which may cause a risk of fire.
4. DO NOT operate the unit if gasoline is spilled. Wipe unit clean and move the unit away from the spill. Avoid creating any ignition until the gasoline has evaporated.
5. DO NOT store the unit near an open flame or any equipment such as a stove, furnace, water heater, etc., which utilizes a pilot light or devices which can create a spark.

IMPORTANT

The following is required by California State law, Section 4442 of the California Public Resources Code. Other states may have similar laws. Federal laws apply on federal lands.

A spark arrester must be added to the muffler of this engine if it is to be used on any forest covered, brush covered or grass covered unimproved land. The arrester must be maintained in effective working order by the operator.

See your engine or equipment dealer for spark arrester muffler options.

IMPORTANT SAFETY WARNINGS

SPRAY PRECAUTIONS:

DANGER

RISK OF INJECTION OR SEVERE CUTTING INJURY!

KEEP CLEAR OF NOZZLE!

**DO NOT DIRECT DISCHARGE STREAM AT PERSONS OR PETS!
ONLY TRAINED OPERATORS SHOULD USE THIS PRODUCT. WHEN
OPERATING THIS UNIT, BASIC PRECAUTIONS SHOULD ALWAYS BE
OBSERVED INCLUDING THE FOLLOWING:**

1. **KEEP AWAY FROM THE SPRAY:**
 - a. Because of the high pressure and velocity of the spray, fluids can penetrate the skin, causing serious injury.
 - b. Never point the gun at yourself or anyone else. Never put your hand, fingers or body directly over the spray nozzle. Always keep operating area clear of all persons. Use **extreme** caution when operating near children.
 - c. If an accident does occur and the spray appears to have penetrated the skin, **SEEK EMERGENCY MEDICAL CARE. DO NOT TREAT AS A SIMPLE CUT.** If you are using cleaning agents, be prepared to tell a physician exactly what kind.
2. **ALWAYS** wear protective goggles when operating the unit to shield the eyes from flying debris and detergents. Other protective equipment such as rubber suits, gloves and respirators are advisable, especially when using cleaning detergents. Use **extreme** caution when operating near children.
3. Stay alert-watch what you are doing. Do not operate the unit when fatigued or under the influence of alcohol or drugs.
4. **NEVER** squeeze the trigger unless securely braced. The thrust from the water traveling through the nozzle may be powerful enough to cause the operator to lose balance if unprepared. **DO NOT** overreach or stand on unstable support. Wet surfaces can be slippery, wear protective foot gear and keep good footing and balance at all times. **NEVER** trigger the gun while on a ladder or roof.
5. Caution should be used when directing spray toward fragile materials such as glass. Shattering could result in serious injury.
6. **ALWAYS** hold on firmly to the gun/wand assembly when starting and operating the unit. Failure to do so can cause the wand to fall and whip dangerously. **NEVER** operate the gun with the trigger wired in the open position. To prevent accidental discharge, the trigger gun should be securely locked when not in use.
7. **DO NOT** direct spray on or into electrical installations of any kind! This includes electrical outlets, light bulbs, fuse boxes, transformers, etc. Severe electrical shock may occur.
8. Even after you shut off the unit, there is high pressure water left in the pump, hose and gun until you release ~~the~~ triggering the gun. Before removing the spray nozzle or servicing the unit, **ALWAYS** shut off the unit and trigger the gun to release trapped pressure.

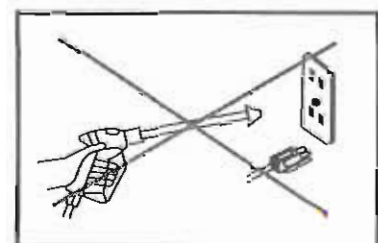
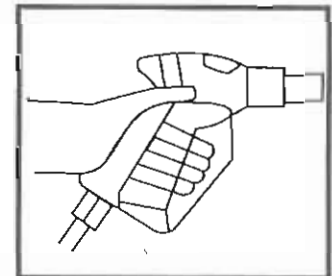
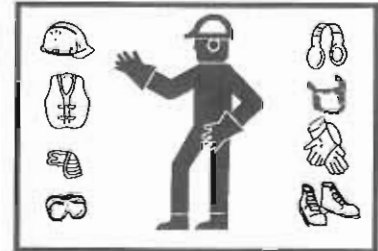
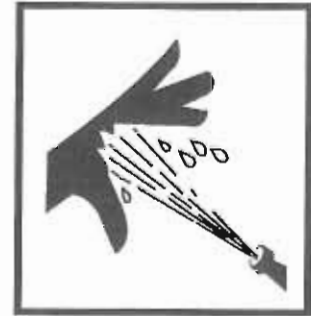



IMPORTANT SAFETY WARNINGS



DETERGENT CLEANING PRECAUTIONS:

1. DO NOT use solvents or highly corrosive detergents or acid type cleaners with this pressure washer. Use only Mi-T-M detergents.
2. KNOW YOUR DETERGENTS! Be prepared to tell a physician exactly what you are using in the event of an emergency. Read the Material Safety Data Sheet (MSDS) provided with your Mi-T-M Detergent and all detergent labels. Follow all appropriate instructions regarding preparation use, safety and transportation. Keep ALL detergents out of the reach of children.
3. DO NOT use this pressure washer to dispense hazardous detergents.
4. DO NOT alter the detergent injection feature in any manner not prescribed in this manual. Use only genuine Mi-T-M replacement parts for necessary repairs.



MISCELLANEOUS SAFETY PRECAUTIONS:

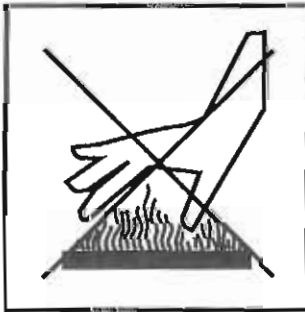
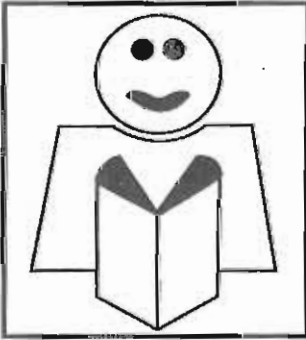

1. NEVER ALLOW CHILDREN OR ADOLESCENTS TO OPERATE THIS UNIT!
2. Read and follow all handling, operations, maintenance and safety instructions listed in this manual and the Engine Operator's manual that accompanies this unit, and provide such information to ANYONE who will be operating this unit.
3. In freezing temperatures, the unit must always be warm enough to ensure there is no ice formation in the pump. DO NOT start this unit if it has been transported in an open or underheated vehicle without first allowing the pump to thaw.
4. When connecting the water inlet to the water supply mains, local regulations of your water company must be observed. In some areas the unit must not be connected directly to the public drinking water supply. This is to ensure that there is no feedback of the detergents into the water supply. (Direct connection is permitted if a back flow preventer is installed.)
5. DO NOT allow any part of your body or the high pressure hose to make contact with the muffler. Avoid dragging the hose over an abrasive surface such as cement. This causes wear and eventual rupturing.
6. High pressure hoses should be inspected daily for signs of wear. If evidence of failure exists, promptly replace all suspect hoses to prevent the possibility of injury from the high pressure spray. If a hose or fitting is leaking, NEVER place your hand directly on the leak.
7. DO NOT operate the unit without all protective covers in place.
8. NEVER run the unit with the governor disconnected or operate at excessive speeds.
9. To reduce the risk of injury, maintain a safe distance for persons while operating this unit. Close supervision is necessary when operating the unit near children.
10. DO NOT leave pressurized unit unattended. Shut off the unit and release trapped pressure before leaving.
11. DO NOT move the unit by pulling on the hose.



IMPORTANT SAFETY WARNINGS



ADJUSTMENT PRECAUTIONS:

1. NEVER alter or modify the equipment, be sure any accessory items and system components being used will withstand the pressure developed. Use ONLY genuine Mi-T-M parts for repair of your pressure washer. Failure to do so can cause hazardous operating conditions and will void warranty.
2. NEVER make adjustments to the machinery while it is connected to the engine without first removing the ignition cable from spark plug. Turning the machinery over by hand during adjustment or cleaning might start the engine and machinery with it, causing serious injury to the operator.
3. Know how to stop the pressure washer and bleed pressures quickly. Be thoroughly familiar with controls.
4. Before servicing the unit; turn the unit off, relieve the water pressure, and allow the unit to cool down. Do not make repairs while unit is running. Service in a clean, dry, flat area. Block the wheels to prevent the unit from moving.
5. Follow the maintenance instructions specified in this manual.



! SAVE THESE INSTRUCTIONS !



JP FEATURES

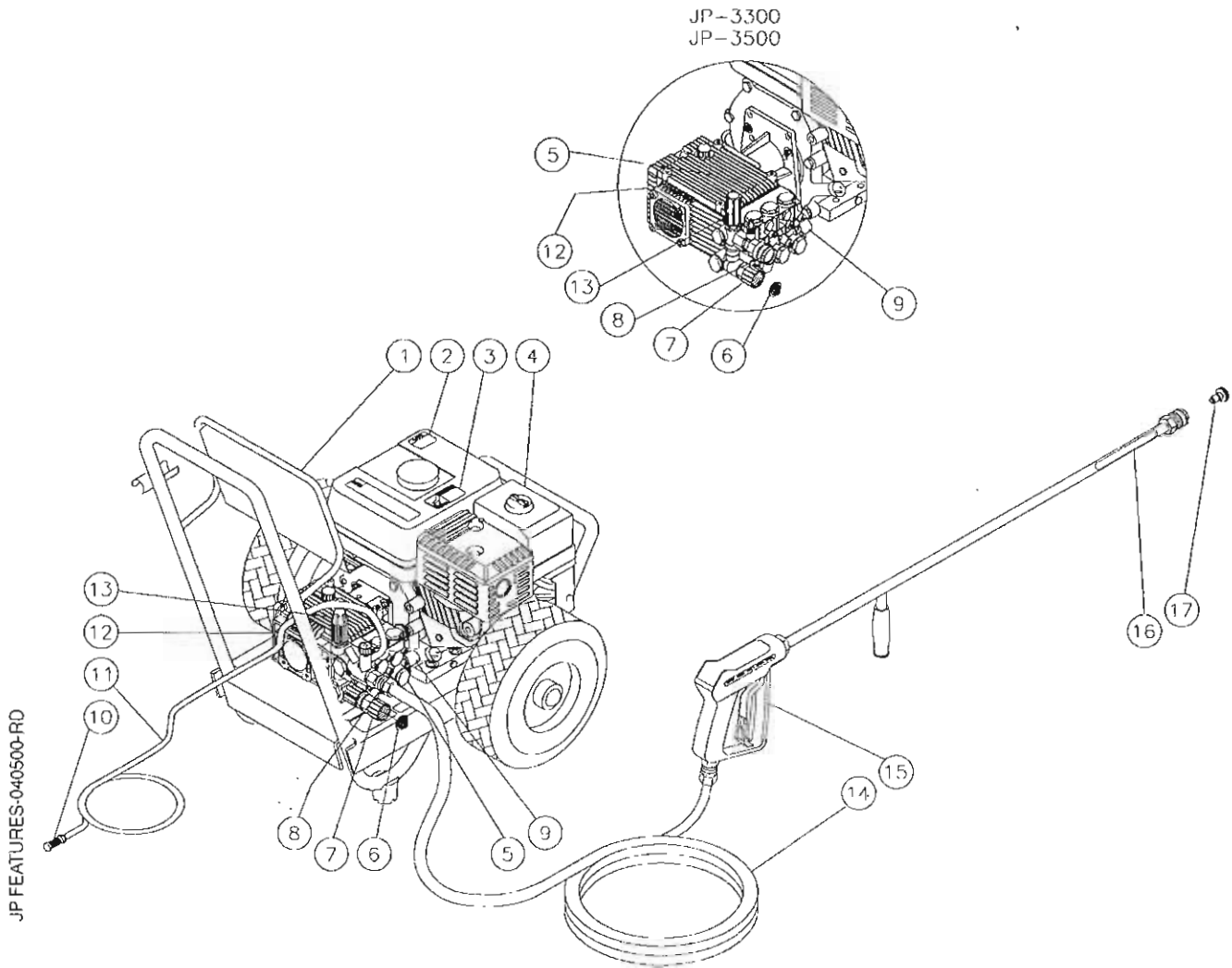

FEATURES LISTING

- | | |
|------------------------------------|--------------------------------------|
| 1. Decal-Warning/Caution/Operating | 10. Detergent Strainer |
| 2. Decal-Caution: Engine Fuel | 11. Detergent Hose |
| 3. Decal-Warning: Muffler Hot | 12. Oil Sight Glass |
| 4. Engine | 13. Adjustment Knob |
| 5. Pump | 14. High Pressure Discharge Hose |
| 6. Water Inlet Strainer | 15. Gun Assembly |
| 7. Water Inlet | 16. Decal-Warning: Risk of Injection |
| 8. Water Outlet | 17. Quick Connect Nozzle |
| 9. Heat Dump Valve | |

CLEANING WITH DETERGENTS:

1. Refer to "Detergent Cleaning Precautions" pg. 6 before working with detergents. Be certain to wear protective safety attire as stated on pg. 10.
2. Prepare detergent solution according to label directions. Never pump acids, alkaline, abrasive fluids or solvents through the unit.
3. Some units are equipped with adjustable detergent knobs. Locate the clear vinyl hose which leads to the pump head.
 - a. If your injector is not equipped with an adjustment knob, the detergent ratio is preset and cannot be adjusted.
 - b. If your injector is equipped with an adjustment knob on the pump head, you may adjust the amount of detergent desired by turning the knob completely counterclockwise to set at the maximum siphon rate.
4. Immerse the detergent strainer into the detergent solution to allow detergent to siphon.
5. With the trigger gun locked in the "OFF" position, securely quick-connect the detergent spray nozzle (#6540° BLACK) into the end of the wand.

NOTE: *This injection system is designed to apply detergents under low pressure only. It will not allow detergent solutions to be introduced into the system unless the nozzle assembly is in the low pressure detergent mode.*

QUICK CONNECT DETERGENT



6. To apply solution; unlock the trigger gun and squeeze the trigger. In a few moments a detergent/water mixture will exit the low pressure nozzle. Start spraying the lower portion of the surface being cleaned and move up, using long overlapping strokes. Applying from the bottom up helps avoid streaking. Allow to soak briefly. DO NOT allow detergent solution to dry on the surface. (Avoid working on hot surfaces or in direct sunlight to minimize the chances of the detergent drying, which may result in damaging painted surfaces.) Be certain to rinse a small section at a time.
7. To rinse; lock the trigger gun in the "OFF" position, securely quick-connect the desired high pressure nozzle into the end of the wand. Unlock the trigger gun and spray. It will take about 30 seconds to purge all detergent from the line. For best rinsing results, start at the top and work down.
8. Siphon a gallon of water through the low pressure detergent injection system after each use. This prevents the possibility of corrosion or detergent residue causing mechanical problems during the next use.

SHUTDOWN:

1. Turn engine "OFF" as directed in the Engine Manual.
2. Turn the water supply "OFF".
3. Pointing the gun in a safe direction, trigger gun momentarily to relieve any trapped pressure.
4. Once pressure is relieved, disconnect the nozzle assembly.
5. Disconnect and drain gun, wand and hoses.
6. Wipe unit clean and store with gun, wand and hoses in a safe non-freezing area.

OPERATION

STOPPING THE ENGINE

To stop the engine in an emergency, simply turn the engine switch to the OFF position. Under normal conditions, use the following procedure.

1. Move the throttle lever to the SLOW position.

Some engine applications use a remotely-mounted throttle control rather than the engine-mounted throttle lever shown here.

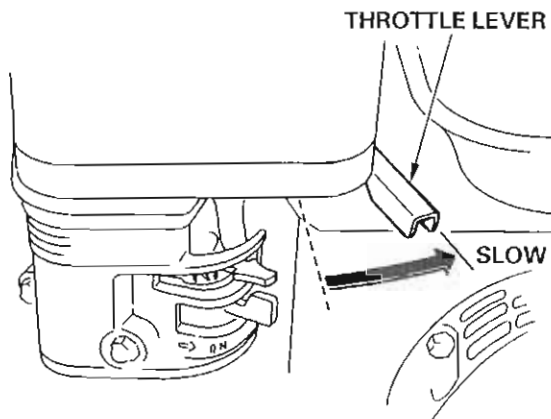

2. Turn the engine switch to the OFF position.

ALL ENGINES EXCEPT QXE2

QXE2 TYPE

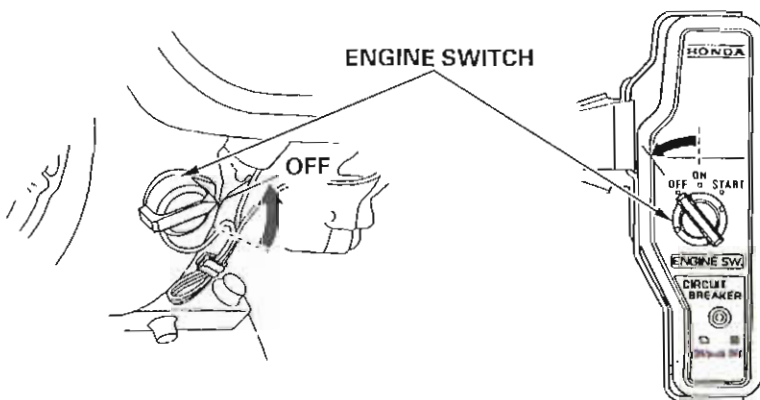

To start a cold engine, move the choke lever to the CLOSED position.

To restart a warm engine, leave the choke lever in the OPEN position.

Some engine applications use a remotely-mounted choke control rather than the engine-mounted choke lever shown here.

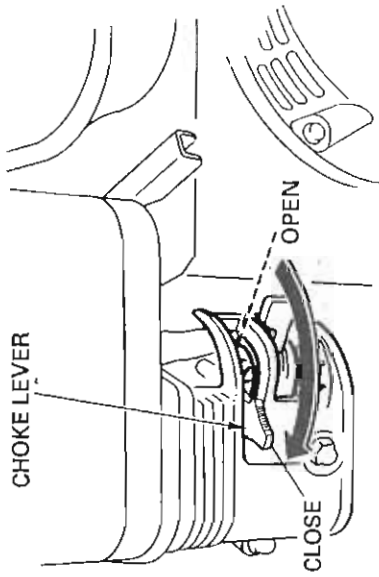

3. Move the throttle lever away from the SLOW position, about 1/3 of the way toward the FAST position.

Some engine applications use a remotely-mounted throttle control rather than the engine-mounted throttle lever shown here.

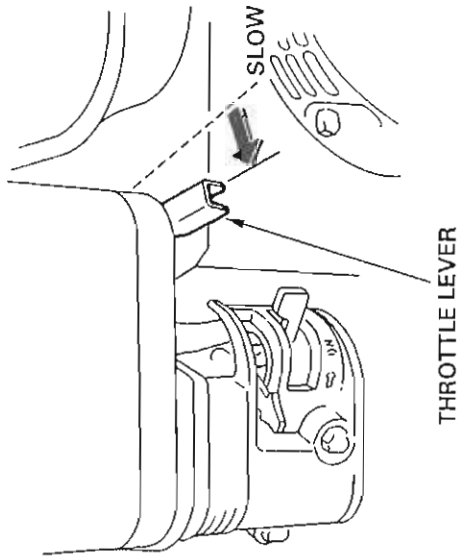

4. Turn the engine switch to the ON position.

ALL ENGINES EXCEPT QXE2

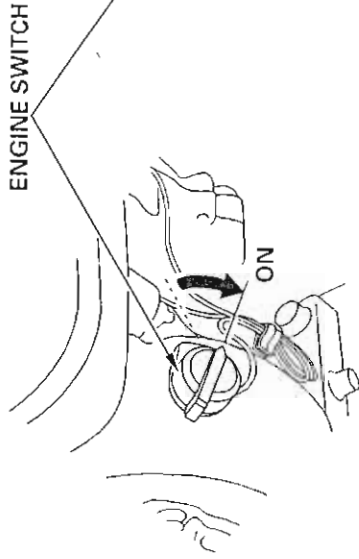

QXE2 TYPE

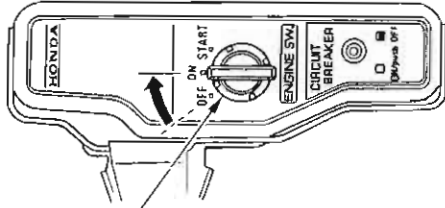

5. Operate the starter.

RECOIL STARTER (all engine types):

Pull the starter grip lightly until you feel resistance, then pull briskly. Return the starter grip gently.

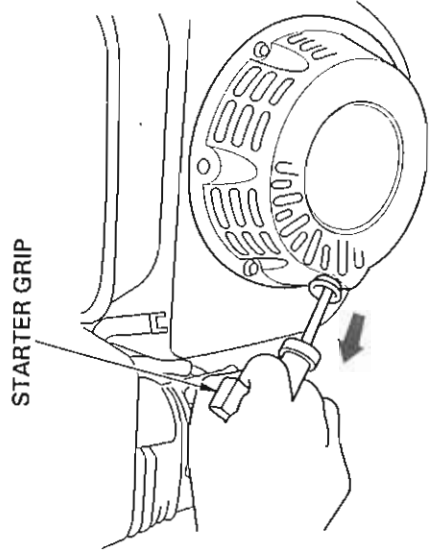

OPERATION

SAFE OPERATING PRECAUTIONS

Before operating the engine for the first time, please review the *IMPORTANT SAFETY INFORMATION* on page 5 and the chapter titled *BEFORE OPERATION*.

⚠ WARNING

Carbon monoxide gas is toxic. Breathing it can cause unconsciousness and even kill you.

Avoid any areas or actions that expose you to carbon monoxide.

Review the instructions provided with the equipment powered by this engine for any safety precautions that should be observed in conjunction with engine startup, shutdown, or operation.

STARTING THE ENGINE

1. Move the fuel valve lever to the ON position.

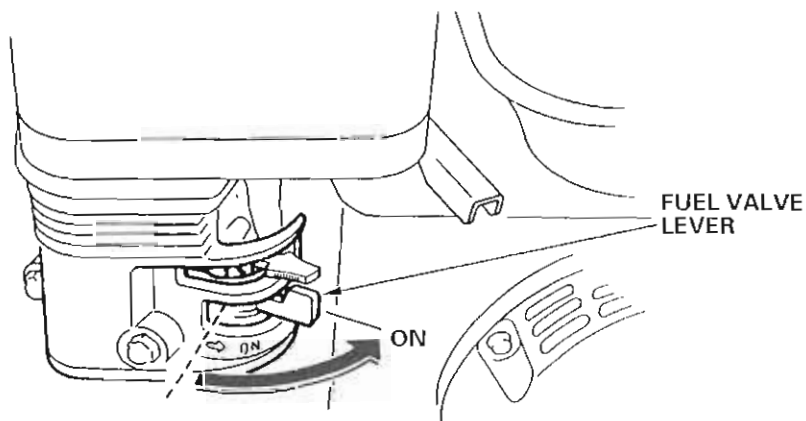

INSTALLATION & PREPARATION

NOZZLE REVIEW:

Various nozzles may be quick-connected into the end of the wand to change the spray pattern or use the detergent feature. When using Quick Connects (Q.C.), be certain the connection is securely locked. If not, the high pressure water may shoot the nozzle from the wand, causing severe injury or serious damage. To determine spray fan, refer to the actual number stamped on the nozzle. The first two digits indicate the spray fan in degrees, i.e.; 00=0°, 15=15°, 25=25°, 65=detergent/low pressure.

1. **The 0° nozzle (RED):** This is a blasting nozzle. It delivers a very concentrated stream of water. Be cautious when using the straight narrow stream. It is not recommended for use on painted or wood surfaces, or items attached with adhesive backings. Uses: Removing weeds from sidewalk cracks, stubborn stains from concrete, masonry, aluminum and steel, caked mud from equipment, and cleaning lawn mower undersides.
2. **The 15° nozzle (YELLOW):** This is a chiseling nozzle. The spray should be directed at a 45° angle to the surface and used like a scraper to remove paint, grease and dirt. Uses: Surface preparation (removing mildew stains and paint chips).
3. **The 25° nozzle (GREEN):** This is a flushing nozzle. This pattern is best suited for flushing dirt, mud, and grime. Uses: Wet sweeping leaves from walks, curbs and driveways, cleaning stable floors, washing swimming pool bottoms, degreasing engines.
4. **The 65° nozzle (BLACK):** This is a low pressure detergent application nozzle. This broad spray pattern distributes solution over vast areas under low pressure. Uses: Detergent application, misting or rinsing.

WARNING

RISK OF INJECTION CAUSING SEVERE INJURY!
NEVER LOOK DIRECTLY AT THE NOZZLE ORIFICE UNLESS IT IS DISCONNECTED FROM THE GUN/WAND ASSEMBLY!

CONNECTION OF Q.C. NOZZLES

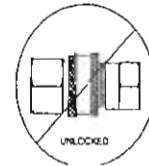

QUICK-CONNECT (Q.C.)

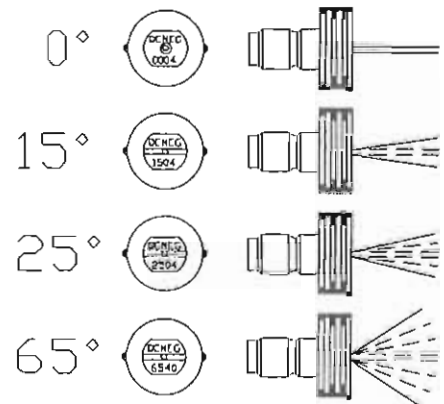

NOZZLE CONNECTION:

1. Be certain the trigger gun is locked in the "OFF" position. See *WARNING*, left.
2. The nozzle assembly should be disconnected from the gun/wand assembly at this by retracting the locking ring on the quick-connect fitting to remove the nozzle.

QUICK-CONNECT FITTING

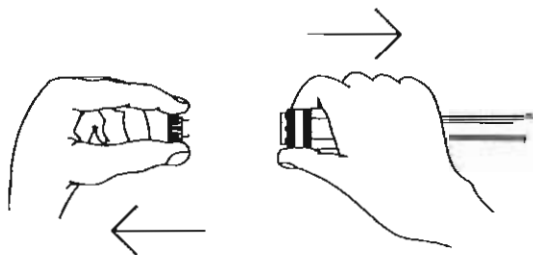

WARNING

RISK OF SEVERE INJURY!
THE TRIGGER GUN SHOULD ALWAYS BE LOCKED IN THE OFF POSITION WHEN NOT IN USE!

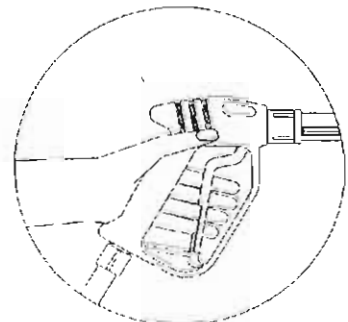

INSTALLATION & PREPARATION

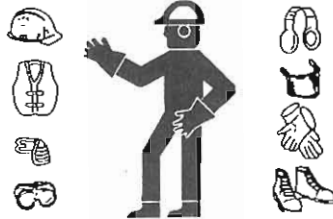

ATTIRE:

Proper attire is essential to your safety. It is advised to utilize whatever means necessary to protect eyes, ears, and skin. Additional safety attire (such as respiratory mask) may be required when using detergent cleaning agents with this washer.



DANGER

RISK OF EXPLOSION OR FIRE!
DO NOT PLACE UNIT IN AN AREA WHERE FLAMMABLE GAS VAPORS MAY BE PRESENT. A SPARK COULD CAUSE AN EXPLOSION OR FIRE!

RISK OF UNIT BURSTING!
DO NOT STORE/OPERATE UNIT IN A FREEZING ENVIRONMENT!



WARNING

RISK OF ASPHYXIATION!
-DO NOT OPERATE IN AN ENCLOSED AREA. USE THIS PRODUCT ONLY IN WELL VENTILATED AREAS!
-THE EXHAUST FROM THE ENGINE CONTAINS CARBON MONOXIDE, A POISONOUS, ODORLESS AND INVISIBLE GAS. BREATHING THIS GAS CAN CAUSE SERIOUS INJURY, ILLNESS & POSSIBLE DEATH.

SETUP:

1. This unit should only be placed on a level surface to ensure proper lubrication for the engine and water pump while operating.
2. Do not use unit in an area:
 - a. with insufficient ventilation.
 - b. where there is evidence of oil or gas leaks.
 - c. where flammable gas vapors may be present.
3. Be certain to block the wheels to prevent the unit from moving while operating.
4. Do not allow the unit to be exposed to rain, snow or freezing temperatures. If any part of the unit becomes frozen, excessive pressure may build up in the unit which could cause it to burst resulting in possible serious injury to the operator or bystanders.
5. Once properly installed, check the oil sight glass on the pump crankcase. Make certain the oil level is in the center of the sight glass before each use. If the level appears low, use Mi-T-M pump oil #AW-4085-0016. DO NOT OVERFILL!



DANGER

RISK OF FIRE!
-DO NOT SMOKE WHILE FUELING!
-DO NOT FILL THE FUEL TANK WHILE UNIT IS RUNNING OR HOT. ALLOW UNIT & ENGINE TO COOL FOR TWO MINUTES BEFORE REFUELING.
-DO NOT FILL FUEL TANK TO POINT OF OVERFLOWING. ALLOW APPROXIMATELY 1/4" OF TANK SPACE FOR FUEL EXPANSION.

ENGINE FUEL TANK:

1. Review "Fire & Ventilation Precautions" pg. 4, before fueling.
2. Locate the Safety Decals on your unit and heed their warnings.
3. A minimum of 86 octane fuel is recommended for use with this unit. DO NOT MIX OIL WITH GASOLINE.
4. Purchase fuel in quantities that may be used within 30 days. Use of clear fresh lead free gasoline is recommended. Leaded gasoline may be used if lead-free is unavailable. DO NOT use gasoline containing methanol or alcohol.
5. Check the engine oil level before starting the engine. (See Engine manual)
6. Fill the fuel tank according to accompanying engine manual instructions.
7. Occasional carburetor and choke adjustments will be necessary for the engine. Refer to the engine manual supplied with this unit for proper adjustment procedures.
8. Review the engine manual accompanying this pressure washer for correct engine start-up and maintenance procedures.



WARNING

RISK OF EXPLOSION OR FIRE!
ALWAYS STORE FUEL AWAY FROM THE WASHER WHILE THE UNIT IS RUNNING OR HOT.

CHECK WATER INLET STRAINER

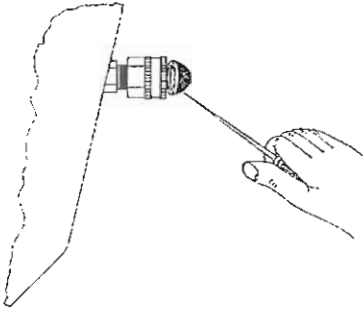

WATER SUPPLY:

1. Select a water supply hose which is a quality grade of garden hose measuring at least 3/4" ID and no longer than 50 feet.
2. Check the water inlet strainer to ensure it is clean and free of any obstructions. Periodic cleaning of the water strainer will help prevent pump problems. As a strainer becomes obstructed, it restricts proper flow of water to the pump. This can result in cavitations which will cause premature failure of pump packings.
 - a. Using a screw driver, remove the screen from the water inlet.
 - b. Clean or replace with Mi-T-M #19-0001 if necessary.
3. Connect the hoses:
 - a. Connect one end of the water supply hose to the water inlet of the unit.
 - b. Connect the other end of the hose to your pressurized water supply.

NOTE 1: Do not use a non-pressurized water supply (i.e. from a pond or well, with this unit.

NOTE 2: If there is a high mineral content in your water, it is highly recommended that an additional water strainer (Mi-T-M #851-0207; be added to the water inlet to help reduce mineral content. Clear both strainers before starting your pressure washer.

- c. Connect the high pressure discharge hose to the water outlet of the unit.
 - d. Securely connect the other end of the hose to the gun assembly
4. Follow the incoming water requirements listed below:
 - a. Water pressure must be a minimum of 20 pounds per square inch (PSI) and a maximum of 125 PSI. (A typical outdoor faucet will generally supply this PSI if turned completely "ON".)
 - b. Incoming GPM must be approximately one gallon more than the outgoing GPM stated on the pressure washer nameplate. (You can check GPM by timing how long it takes to fill a 5 gallon container.)
 - c. Incoming water temperature must not exceed 125°F. Excessive pump damage may result if the water temperature exceeds this acceptable level.
5. Never allow the unit to operate without the incoming water line attached and the water supply completely turned on.

 **CAUTION**

RISK OF UNIT DAMAGE!

DO NOT OVERTIGHTEN THE UNLOADER. BREAKAGE COULD RESULT IN IMMEDIATE LOSS OF WATER PRESSURE AND COSTLY REPAIRS.

UNLOADER:

The unloader valve on your machine is equipped with an adjustment knob to adjust the pressure. Should less pressure be required, simply turn the adjustment knob counterclockwise. To set back to maximum, turn adjustment knob completely clockwise. **DO NOT OVERTIGHTEN!**

HEAT DUMP VALVE:

To ensure the water temperature does not exceed acceptable levels, never allow the pressure washer to operate in the bypass mode (with the unit running and the trigger gun closed) for more than three minutes.

A heat dump valve has been added to this unit to protect the pump. It may begin to open and release water if the water temperature in the pump has exceeded 140°F. This will allow fresh, cool water to enter the system.